

Captain Seat Assembly

(After 8/31/02)

Captain Seats recline approximately 90° - 114° for semi recline backs and 90° - 170° for full recline back models. Adjustable depths are (16, 17, 18" deep for 18" wide seats). Recline release levers are standard on the right side. Semi recline left side release levers can be ordered as a special with a new captain seat. All full recline captain seats must be ordered as a "special order" to have the limit switch sensor actuator hardware mounted on the right side.

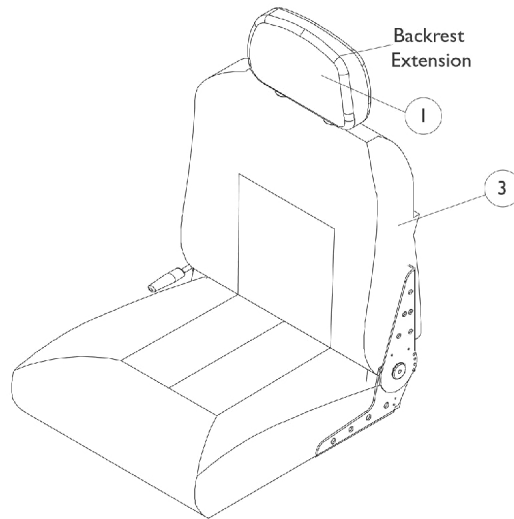

Semi Recline Captain Seat

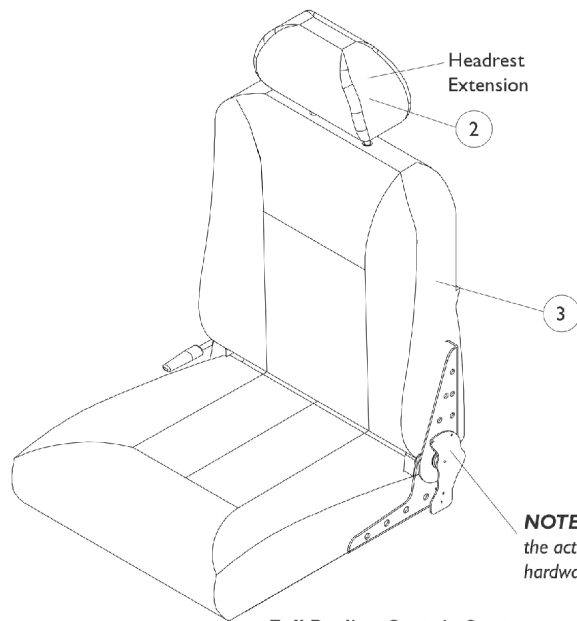

Full Recline Captain Seat

NOTE: Full recline captain seats **do not include** the actuator hardware. See seat frame and actuator hardware page.

Captain Seat Assembly

(After 8/31/02)

Captain Seats recline approximately 90° - 114° for semi recline backs and 90° - 170° for full recline back models. Adjustable depths are (16, 17, 18" deep for 18" wide seats).

Recline release levers are standard on the right side. Semi recline left side release levers can be ordered as a special with a new captain seat. All full recline captain seats must be ordered as a "special order" to have the limit switch sensor actuator hardware mounted on the right side.

Backrest/Headrest Extensions and Captain Seat Assemblies

Item Number	Description	All Grey Fabric	All Grey Vinyl	All Tan Vinyl
1	Backrest - For Semi Recline	1106969-NLA	1108408	1106968-NLA
2	Headrest - For Full Recline	1106967	1108409-NLA	1106966
3	18" Wide - Semi Recline with Backrest	1109254-NLA	1109242	1109248-NLA
3	18" Wide - Full Recline with Backrest	1109257-NLA	1109245-NLA	1109251-NLA

NOTE: When converting from a semi recline to a full recline captin seat, a limit switch sensor harness part # 1074983 must be ordered as well. See page titled "Captain Seat Frame and Actuator Hardware."

NOTE: Actuator mounting hardware is not included with captain seat, see page titled, "Captain Seat Frame and Actuator Hardware."

NOTE: New seat mounting screws #1025713 in (4) are required when converting a captain seat available before 9/1/02 to a captain seat available after 8/31/02.