

Anti-Tippers, Long (For 19 and 20" FSTF) (A1580, A1580P)

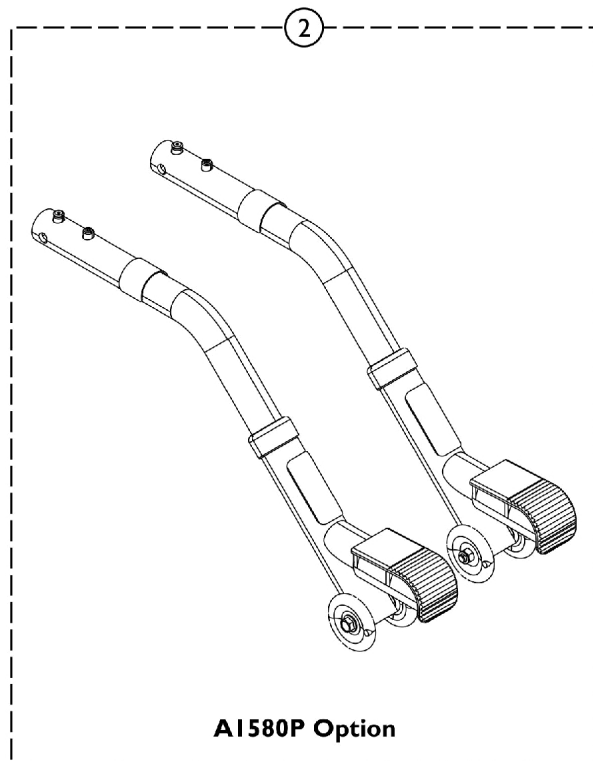
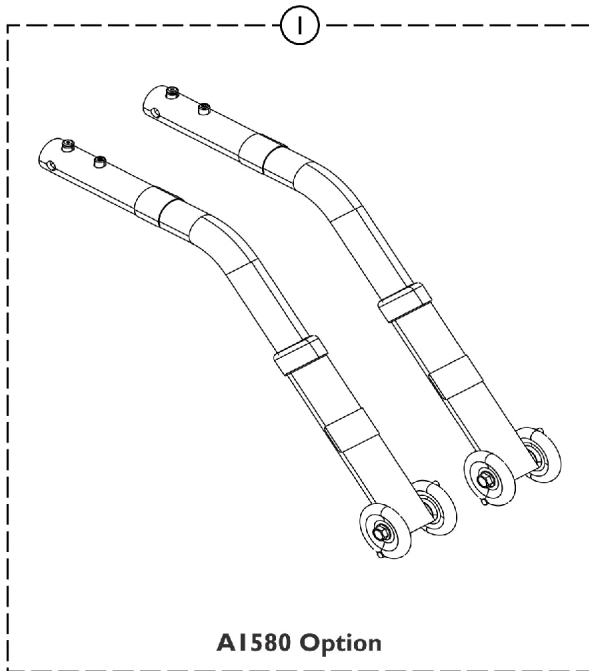

Anti-Tippers, Long (For 19 and 20" FSTF) (A1580, A1580P)

Item Number	Note	Part Number	Description	Quantity Per	
				Package	Assembly
1	A	60108489	Anti-Tip Assembly, Long (Pair)	2	1
			Anti-Tip Assembly, Long	1	2
			NLA - Label, Warning, Anti-Tip	1	2
			NLA - Label, Warning, Anti-Tip	1	2
2	A	60108492	Anti-Tip Assembly w/ Tipping Aid, Long (Pair)	2	1
			Tube, Grey Anti Rattle	1	2
			Tube, Anti-Tip w/ Tipping Aid Long	1	2
			Cap, Foot Support	1	2
			Screw, Hex Head Cap (M5 x .8 x 45mm)	1	2
			Wheel, 37.6	1	4
			Nut, Lock (M5 x .8)	1	2
			Spring, Torsion with Button Lock	1	2
			Button, Spring	1	2
			NLA - Anti-Rattle (1")	1	2
			NLA - Label, Warning, Anti-Tip	1	2
			NLA - Label, Warning, Anti-Tip	1	2

NOTE: A - Used for 19" and 20" Front Seat To Floor (FSTF) heights only.