

# General Tilt Actuator Module (GTAM) TDX SP w/ 4-Pole Motors & Formula (CGT/CGTE)

Round Back Cane shown  
For reference only

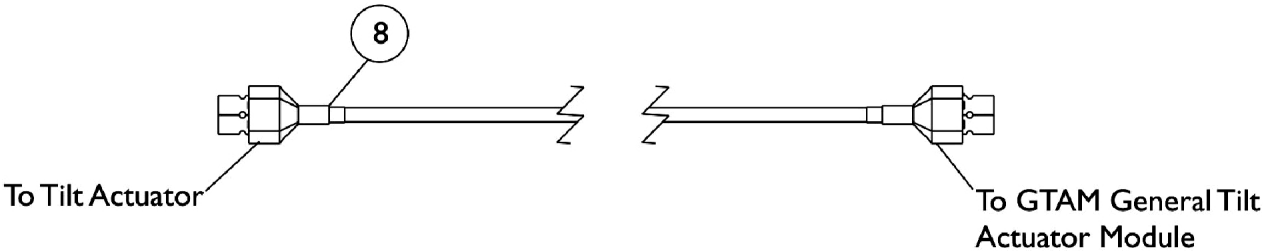
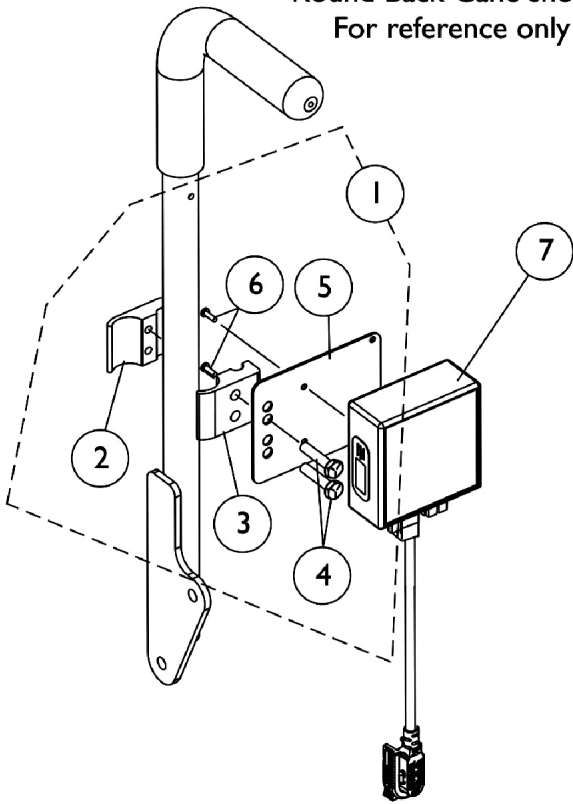

## General Tilt Actuator Module (GTAM) TDX SP w/ 4-Pole Motors & Formula (CGT/CGTE)

Item Number	Note	Part Number	Description	Quantity Per	
				Package	Assembly
1	A	1142226	Kit, SNP/DI, 4WSB, S4WSB, GTAM, AUX12M6, AUX34M6, R/L Module Mounting Hardware For Round Back Canes	1	1
2			NLA - Half Clamp, Threaded Holes	1	1
3			Half Clamp, Non-Threaded Holes	1	1
4			NLA - Screw, Hex Head (1/4-20 x 1-1/8")	1	2
5			Plate, Mounting	1	1
6			Screw, Phillips Pan Head (#4-40 x 3/8")	1	2
			Tie Wrap (5-5/8" L)	1	5
7	B	1140037	Module, General Tilt Actuator (GTAM) - MK6i (54" L)	1	1
8		1101400	Harness, ELRPW Power Legrest - Right	1	1
	C	1095503-NLA	NLA - Package, Tie Wrap (5-5/8" L)	10	1

NOTE: A - Includes items 2-6 and (Cable Ties not shown).  
 B - The General Tilt Actuator Module (GTAM) is used with a TDX SP w/ 4-Pole Motors and Formula (CGT/CGTE) System with a Conventional Tilt Actuator Motor. Item #8 ELRPW Power Legrest Harness - Right is used to connect the GTAM to the Tilt Actuator Motor  
 C - Not Shown