

# Drive Wheels for GB TrueTrack Heavy Duty (TTHD) Motors

**NOTE:** Gearless/Brushless TrueTrack Heavy Duty (TTHD) motors were introduced and offered as an ON-chair option to Storm Arrow models from 2/6/03 thru 1/25/04 (3/14/04 for VA Government orders). On 1/26/04 (3/15/04 for VA Government orders) Gearless/Brushless TrueTrack Heavy Duty (TTHD) motors became standard on Storm Arrow and optional on Ranger X and Torque SP/SE & Torque 3 models.

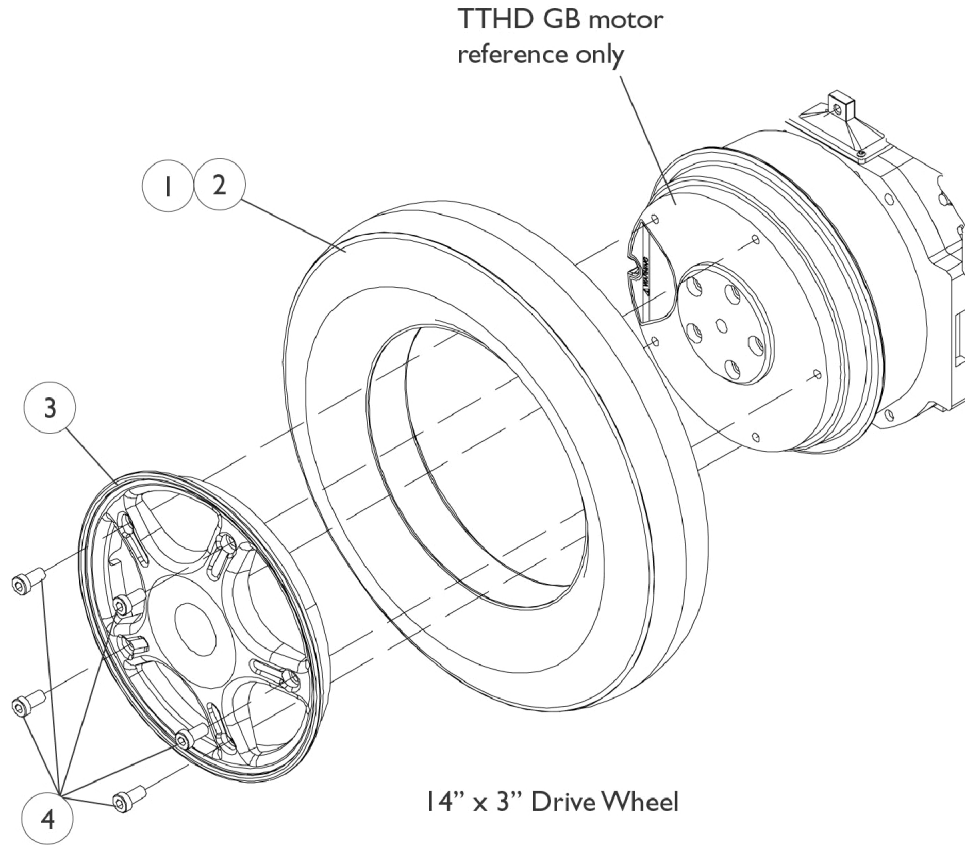

# Drive Wheels for GB TrueTrack Heavy Duty (TTHD) Motors

**NOTE:** Gearless/Brushless TrueTrack Heavy Duty (TTHD) motors were introduced and offered as an ON-chair option to Storm Arrow models from 2/6/03 thru 1/25/04 (3/14/04 for VA Government orders). On 1/26/04 (3/15/04 for VA Government orders) Gearless/Brushless TrueTrack Heavy Duty (TTHD) motors became standard on Storm Arrow and optional on Ranger X and Torque SP/SE & Torque 3 models.

Item Number	Note	Part Number	Description	Quantity Per	
				Package	Assembly
1		1118273	Tire, Pneumatic with Instruction Sheet, Grey (14" x 3")	1	1
1	B,B1	1118274	Kit, Tire w/ Foam Fill Insert and Instruction Sheet, Grey (14" x 3")	1	1
2		1118275	Kit, Inner Tube w/ Instruction Sheet, Black (14 x 3")	1	1
3	B,B1	1116701	Kit, Rim 8" w/ Instruction Sheet (For 14 x 3" Wheel)	1	1
4	B,B1	1113320	Screw, Socket Head (M8 x 1.25 x 16mm)	1	5
	A	1153683	Screw, Socket Head (M8 x 1.25 x 25MM)	1	3
	A,C	1114830-NLA	NLA - Instruction Sheet, Rim and Tire Replacement	1	1
<p>NOTE: A - Not Shown            B - When ordering a new flat free tire, rim or 16MM wheel mounting screws item #4, it is recommended to order 3 ea. of part #1153683 25MM screws as well.            B1 - The 25MM screws are inserted a 1/4" in every other mounting hole on the motor to compress the flat free and make it easier to install the 5 shorter 16MM screws.            C - Item is no longer available from the Invacare Service Parts Department. Refer to the Invacare Website under "Product Literature Search". Enter the part number in the "Keywords" field and download a free PDF version copy.</p>					