

Electronics

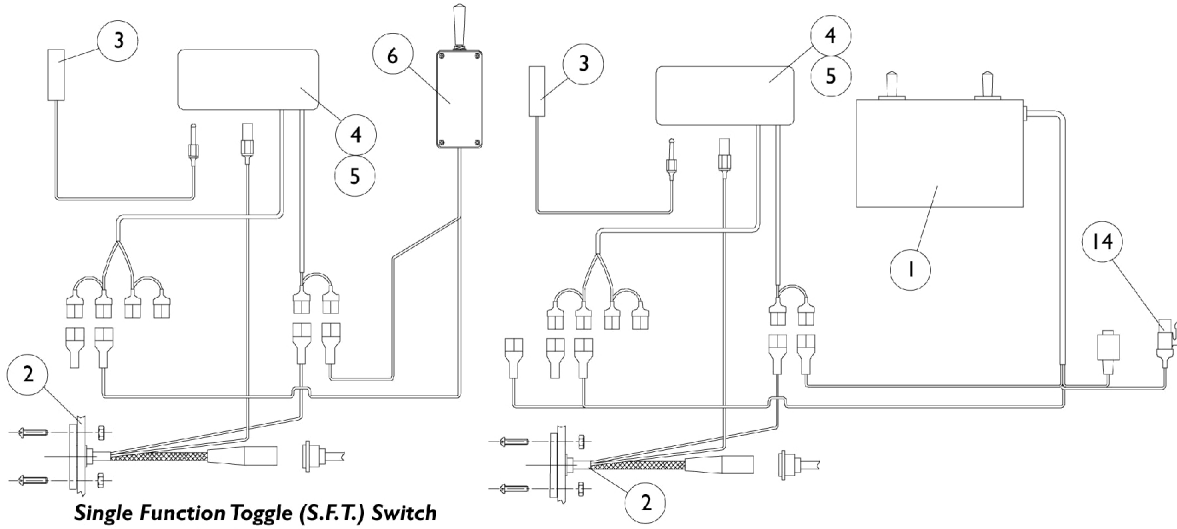

Single Function Toggle (S.F.T.) Switch and Drive Lockout.
(Standard On-Chair Before 2/16/98)

DAD Box and Drive Lockout

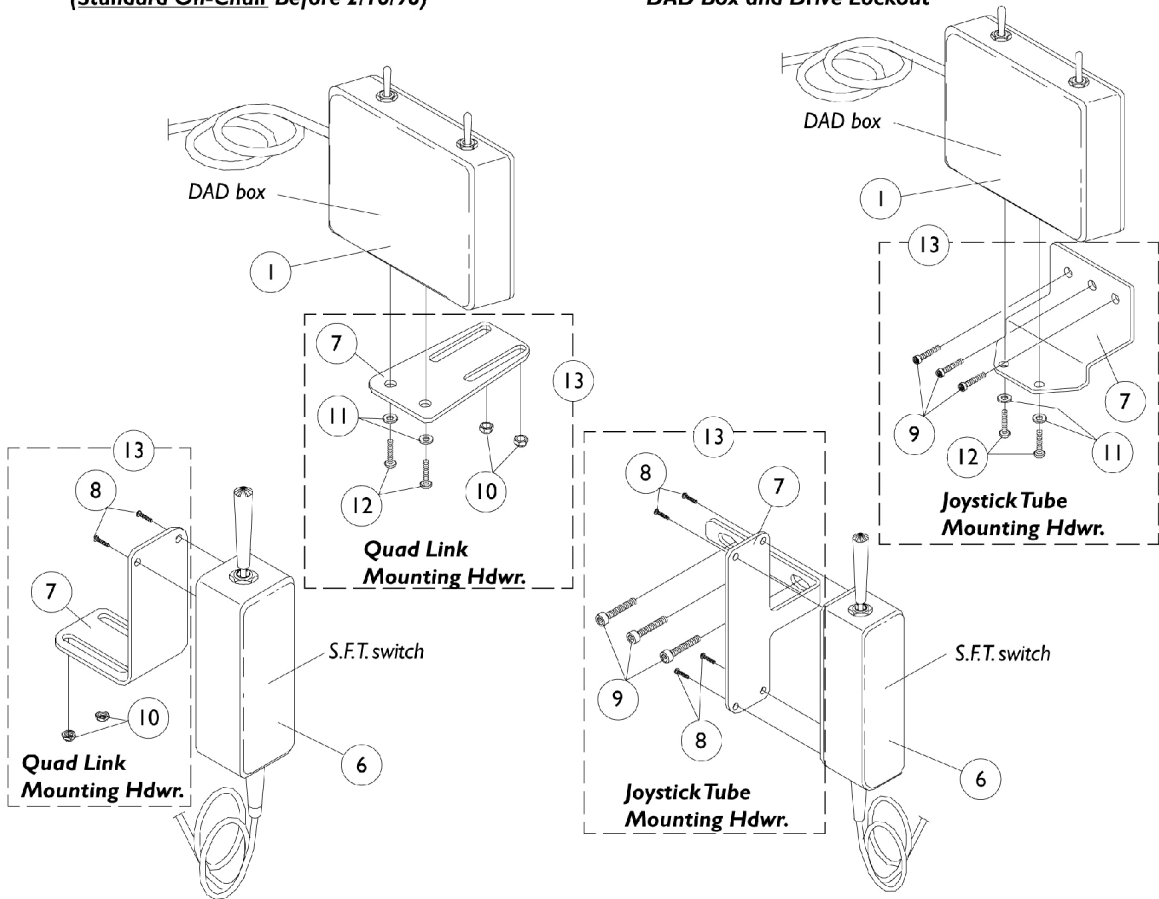

DAD box

DAD box

Quad Link Mounting Hdw.

Joystick Tube Mounting Hdw.

Quad Link Mounting Hdw.

Joystick Tube Mounting Hdw.

S.F.T. switch

S.F.T. switch

Electronics

Item Number	Note	Part Number	Description	Quantity Per	
				Package	Assembly
1		0012700-NLA	NLA - D.A.D. Box with Tilt Harness	1	1
2		0227700-NLA	NLA - Harness, Power, Storm	1	1
3		0018500-NLA	NLA - Switch, Limit	1	1
4	J	See Note	See Footnote	1	1
5		1077304	Dual Lock, Male/ Female Adhesive Back (1" x 3")	1	1
6	A	0037400-NLA	NLA - Switch, S.F.T.	1	1
7	I	0224202-NLA	NLA - Plate, S.F.T. Switch, Joystick Tube Mounting	1	1
7	H	0224702	Plate, S.F.T. Switch, Quad Link Mounting	1	1
7	I	0225402-NLA	NLA - Plate, D.A.D. Box, Joystick Tube Mounting	1	1
7	H	0225602	Plate, D.A.D. Box, Quad Link Mounting	1	1
8		313329-NLA	NLA - Screw, Phillips Pan Head (#6-32 x 1/2")	1	4
9		7930304-NLA	NLA - Screw, Socket Head (1/4-20 x 1-1/4")	25	2
10		317601-NLA	NLA - Locknut, Low Profile (#10-32)	1	3
11		0224806-NLA	NLA - Washer (#10)	1	2
12		0067106-NLA	NLA - Screw, Phillips Pan Head (#10-32 x 1/2")	1	2
13	I	1077270-NLA	NLA - Mounting Plate Assembly, S.F.T. Switch, Joystick Tube	1	2
13	H	1077271-NLA	NLA - Mounting Plate Assembly, S.F.T. Switch, Quad Link	1	1
13	I	1077268	Mounting Plate Assembly, D.A.D. Box, Joystick Tube	1	1
13	H	1077269	Mounting Plate Assembly, D.A.D. Box, Quad Link	1	1
14		0238800-NLA	NLA - Switch, Limit Override (DAD Box)	1	1
	C	0014800	Cable, Interface, Invacare R.I.M. Control	1	1
	C	0200300-NLA	NLA - Cable, Interface, Power Legs Combined	1	1
	C,D,F	1082365-NLA	NLA - Controller, Up-Gr W.S.T.- D.A.D.Relay	1	1
	C,E,G	1084174	Controller, Up-Gr W.S.T.-D.A.D. Relay	1	1
	B,C	1084706	Package, Decals, D.A.D. Relay Controller Upgrade	5	1

NOTE: A - Old style S.F.T switch doesn't have the drive lockout feature built in.
 B - Decal Package is supplied in all upgrade kits and covers all systems. Decals not sold separately. Decals are labeled "Tilt," "Recline," "Drive Lockout," "PLeg" and "Caution While Propelling."
 C - Not shown.
 D - Includes Items 1, 7, 9 -12 and 14
 E - Includes Items 1-5, 7, 9-12 and 14
 F - Before 2/16/98
 G - After 2/15/98
 H - Use with Quad Link before 4/07/06
 I - Use with Joystick Tube and Quad Link (QLA) after 4/06/06
 J - Part is no longer serviceable in the field.