

Power Articulating Legrest ELRPW (Between 5/1/02-7/26/04)

NOTE: One key visual difference between power legrest before 5/01/02 and after 4/30/02 is the motor actuator as shown below. This will help to identify what version a Customer is using.

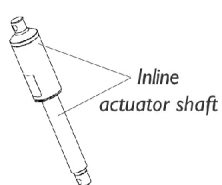

Before 5/01/02

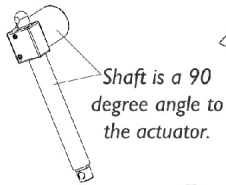

After 4/30/02

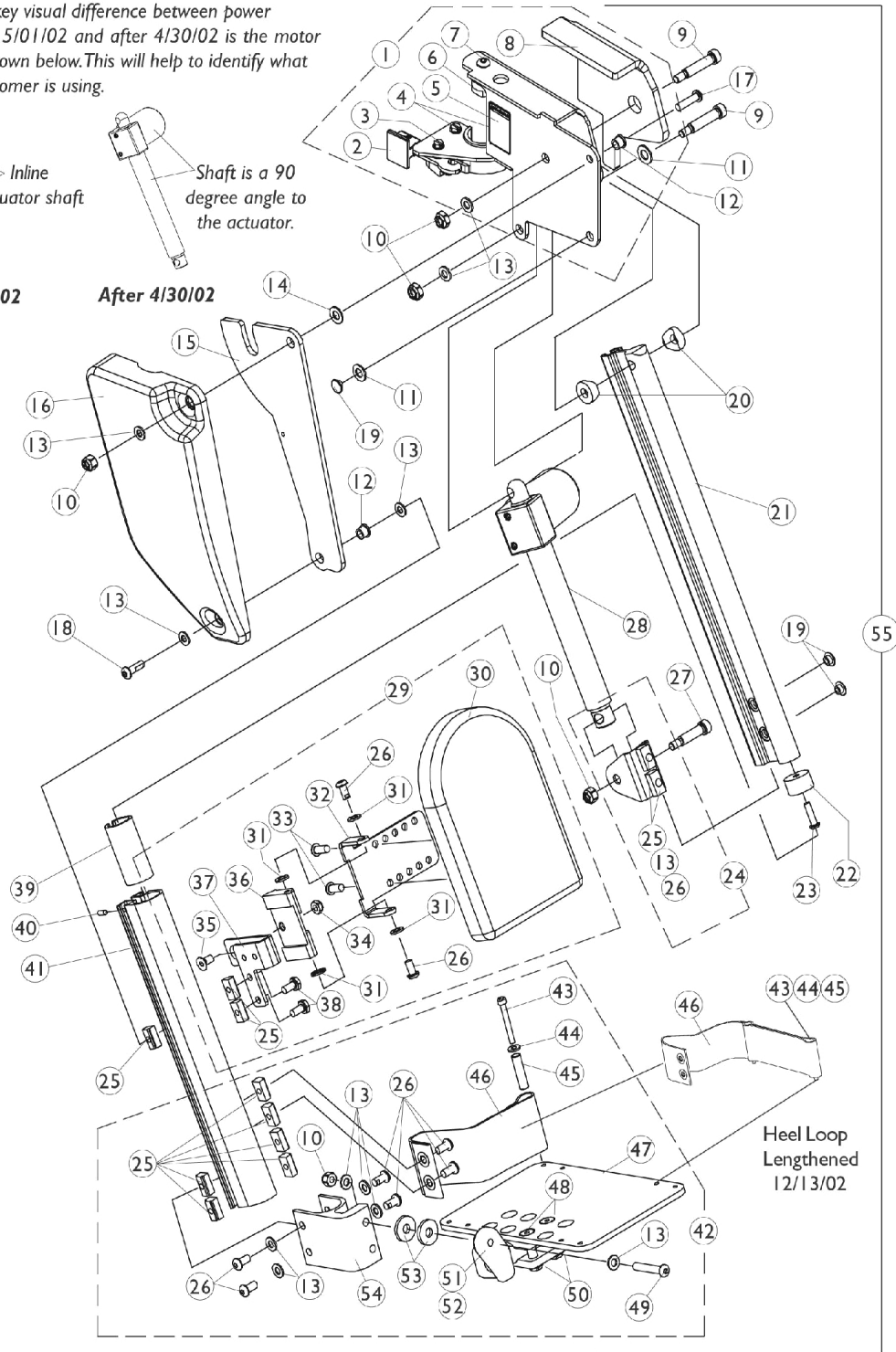

Heel Loop Lengthened 12/13/02

Power Articulating Legrest ELRPW (Between 5/1/02-7/26/04)

Item Number	Note	Part Number	Description	Quantity Per	
				Package	Assembly
1	A	1111720-NLA	NLA - Legrest Support Assembly, Sector, Black - Right	1	1
1	A	1111721-NLA	NLA - Legrest Support Assembly, Sector, Black - Left	1	1
2		1025454	Housing, Latch - Right	1	1
2		1025455	Housing, Latch - Left	1	1
3		1017423	Screw, Slotted Hex Washer Head w/ Patch (#10-32 x 1/2")	1	1
4		1025451	Screw, Slotted Hex Washer Head (#10-32 x 5/8")	1	2
5		1079203	Decal, Warning Pinch Point	1	1
6		1099685	Plug, Pivot	1	1
7		1091870	Screw, Socket Button Head w/ Patch (1/4-20 x 3/4")	1	1
8	J	1110968-NLA	NLA - Pad, Cushion - Right	1	1
8	J	1110969-NLA	NLA - Pad, Cushion - Left	1	1
9		1025351-NLA	NLA - Screw, Shoulder Hex Socket Head (5/16" x 1-1/4", 1/4-20)	1	2
10		1025736	Locknut (1/4-20)	1	5
11		1025704	Washer, Flat (5/16 x 5/8 x 1/16")	1	2
12		1099671	Bearing, Flange (1/4 x 5/16" Long)	1	2
13		1026907	Washer (1/4 x 1/2 x 1/16")	1	12
14		1012371	Washer, Nylon (3/8 x 7/8 x 1/16")	1	1
15		1110745-NLA	NLA - Plate, Pivot	1	1
16		1110746	Cover, Legrest Support - Right	1	1
16		1110747	Cover, Legrest Support - Left	1	1
17		1009837	Screw, Socket Button Head (1/4-20 x 1")	1	1
18		1091870	Screw, Socket Button Head w/ Patch (1/4-20 x 3/4")	1	1
19		1101883	Glide	1	3
20		0175600	Spacer, Coved (5/16 x 3/4 x 3/8")	1	2
21		1110741	Extrusion, Internal Slide (14-1/4" L)	1	1
22		1099702	Glide, Internal	1	1
23		1018846	Screw, Socket Button Head (#10-24 x 3/4")	1	1
24	B	1110972	Actuator Motor Bracket Assembly	1	1
25		1082699	T-Nut (1/4-20)	1	11
26		1100023	Screw, Button Head w/ Patch (1/4-20 x 1/2")	1	10
27		1087417-NLA	NLA - Screw, Shoulder Hex Socket Head (5/16" x 1", 1/4-20)	1	1
28		1110724	Motor, Actuator - Right	1	1
28		1110725	Motor, Actuator - Left	1	1
29	C	8881110977	Calf Pad Assembly with Hardware - Right	1	1
29	C	8881111715	Calf Pad Assembly with Hardware - Left	1	1
30		88804529X003	Pad, Legrest, Vinyl - Right	1	1
30		88804529X004	Pad, Legrest, Vinyl - Left	1	1
	D,G	1110748-NLA	NLA - Hardware, Calf Pad Bracket	1	1
31		1026033	Washer, Nylon (1/4 x 1/2 x 1/16")	1	4
32		1099700-NLA	NLA - Bracket, Calf Pad Mounting, Black	1	1
33		1029157	Screw, Phillips Pan Head w/Patch (#10-32 x 7/8")	1	2
34		1025765	Locknut (1/4-28)	1	1

Power Articulating Legrest ELRPW (Between 5/1/02-7/26/04)

Item Number	Note	Part Number	Description	Quantity Per	
				Package	Assembly
35		1074191-NLA	NLA - Screw, Socket Flat Head (1/4-28 x 1/2")	1	1
36		1099690-NLA	NLA - Block, Calf Pad	1	1
37		1111716	Bracket, Calf Pad Block Mounting, Black - Right	1	1
37		1111717	Bracket, Calf Pad Block Mounting, Black - Left	1	1
38		1078214	Screw, Hex Head w/ Patch (1/4-20 x 1/2")	1	2
39		1110742	Bushing, Sleeve	1	1
40		1079151-NLA	NLA - Pin, Roll (5/64 x 5/8")	1	1
41		1110734-NLA	NLA - Extrusion, External - ELRPW (10-1/2" L)	1	1
42	E	1101114	Footplate Assembly, Adjustable Angle, Black - Right (5-1/4" W)	1	1
42	E	1101115	Footplate Assembly, Adjustable Angle, Black - Left (5-1/4" W)	1	1
43		1023965-NLA	NLA - Screw, Socket Head (#10-32 x 1-1/2")	1	2
44		1028516	Washer, Steel (3/16 x 7/16 x 1/16")	1	2
45		1015629-NLA	NLA - Bushing	1	2
46	H	1101268	Heel Loop Assembly - Right	1	1
46	H	1101269	Heel Loop Assembly - Left	1	1
47		1060427-NLA	NLA - Footplate, Adjustable Angle, Large, Black (5-1/4" W x 8" L)	1	1
48		1029545	Screw, Socket Flat Head (1/4-20 x 3/4")	1	2
49		1008495	Screw, Socket Button Head (1/4-20 x 1-1/2")	1	1
50		1082686	Nut, Barrel, Hex Head (1/4-20 x 11/16")	1	2
51		1052102	Hinge, Footplate - Right	1	1
51		1052103	Hinge, Footplate - Left	1	1
52		1048816	Screw, Nylon Adjustment (1/2-13 x 7/8")	1	1
53		1016301	Washer, Nylon (5/16 x 7/8 x 1/8")	1	2
54		1099678	Extrusion, Footplate Adapter	1	1
55	F,F1,I	1110743-NLA	NLA - Legrest Assembly, Power Articulating, Sector, Black (13"-20" Range) - Right	1	1
55	F,F1,I	1110744-NLA	NLA - Legrest Assembly, Power Articulating, Sector, Black (13"-20" Range) - Left	1	1

NOTE: A - Includes items 2-8
 B - Includes items 13, 25 and 26
 C - Includes Items 25, 26 and 30-38
 D - Includes Items 25, 26, 31-36, 38
 E - Includes Items 10, 13, 25, 26 and 43-54
 F - After 4/30/02 MKIV T.A.C. controller software changed from 1.1 to 1.2 to accommodate power articulating legrest made after 4/30/02.
 F1 - A new MKIV T.A.C. controller part number 1109552 must be ordered when replacing power articulating or non-articulating legrest made before 5/1/02. Verify software version before ordering.
 G - Not Shown
 H - Heel loop service part was lengthened 12/13/02. Verify with customer if longer heel loop is present. Order in pairs when needed along with 2 each of items 43, 44 and 45.
 I - Due to a product enhancement that provides a higher pivot point at the knee, a customer must order a complete right and left side legrest assembly. see page titled "Power Articulating Legrest After 7/26/04".
 J - No longer available individually. See Item number 1 for replacement.