

Swingarm and Caster with Hardware - Invacare 300

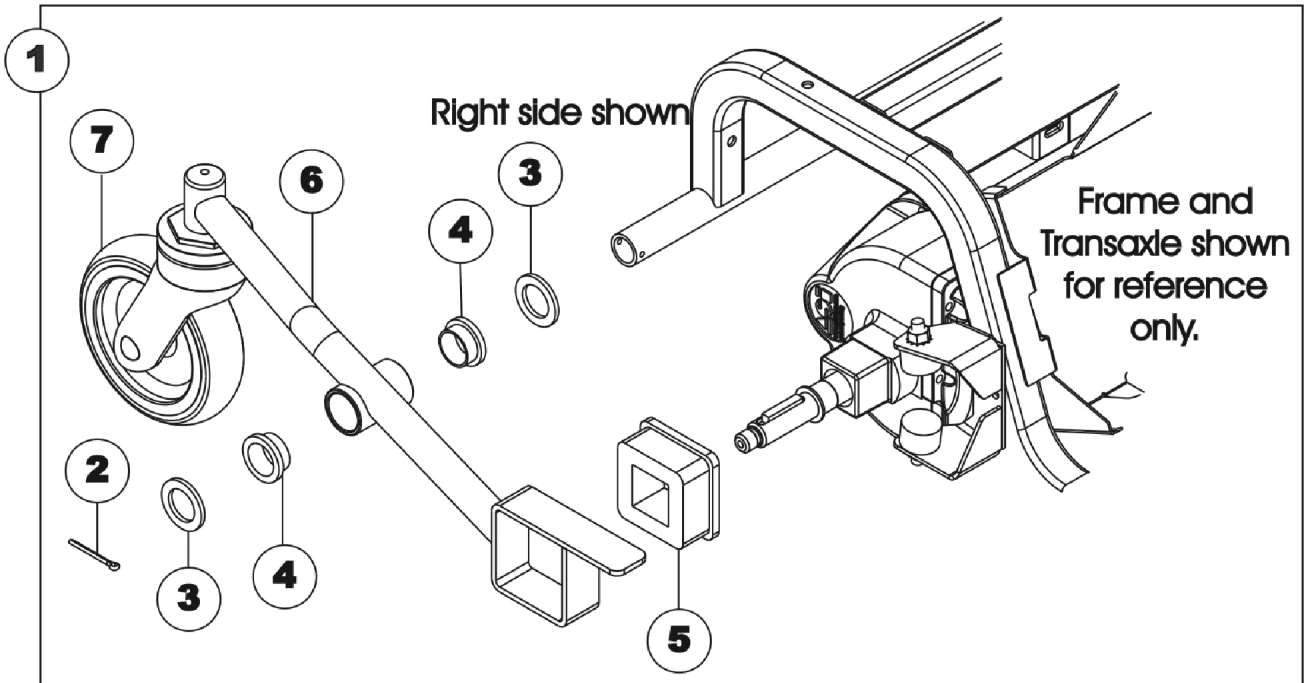

Item Number	Note	Part Number	Description	Quantity Per	
				Package	Assembly
1	A,B	1120433-NLA	NLA - Frame, Swingarm Assembly (Invacare 300 Scooter)	1	1
2			NLA - Pin, Cotter (1/8 x 1-1/4")	1	2
3			NLA - Washer, Steel (29/32 x 1-3/8 x 1/8")	1	4
4			NLA - Washer, Shoulder	1	4
5			NLA - Element, Viscous	1	2
6			NLA - Swingarm with Caster - Right (Invacare 300 Scooter)	1	1
6			NLA - Swingarm with Caster - Left (Invacare 300 Scooter)	1	1
7			NLA - Caster, Swivel (5") (Invacare 300 Scooter)	1	2

NOTE: A - Includes: Items 2-7; Assembly Includes both Right and Left sides.
 B - The Swingarm assembly includes the caster.