

Casters, Forks and Hardware

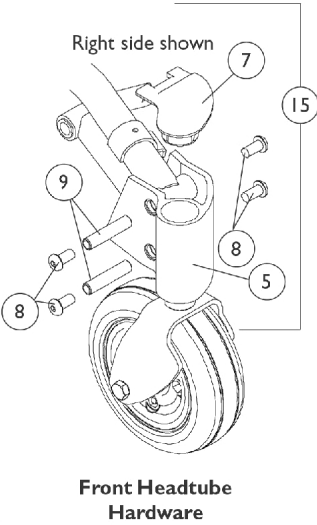
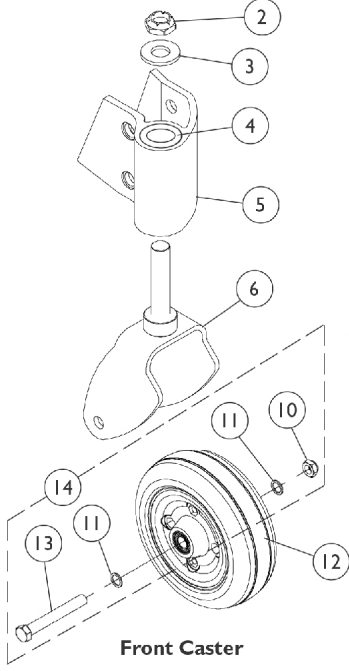
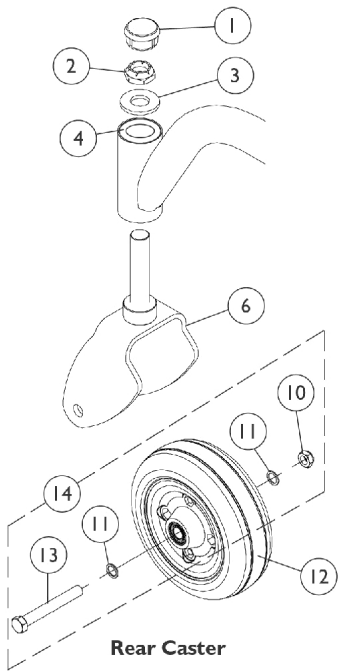

Casters, Forks and Hardware

Item Number	Note	Part Number	Description	Quantity Per	
				Package	Assembly
1		1105026	Plug Button, Head Tube, Black	1	1
2		1028550	Locknut (5/8-18)	1	1
3		1041444	Washer, Nylon (5/8 x 1-5/16 x 1/8")	1	1
4		40117X006	Bearing (5/8")	1	2
5		1109014-NLA	NLA - Headtube, Caster, Black - Right	1	1
5		1109015-NLA	NLA - Headtube, Caster, Black - Left	1	1
6	E	1123904-NLA	NLA - Kit, Fork and Stem, Black (Pair)	2	1
6	F	1106355	Fork and Stem Assembly	1	1
7		1105024	Cap, Front Head Tube, Black - Right	1	1
7		1105025	Cap, Front Head Tube, Black - Left	1	1
8		1109222	Screw, Socket Button Head Cap (3/8-24 x 3/4")	1	4
9		1106511	Bushing (3/8 x 1/2 x 2-1/8")	1	2
10		1025734	Locknut (7/16-20)	1	1
11		1025724	Washer, Steel (15/32 x 5/8 x 3/64")	1	2
12	C	1072014-NLA	NLA - Wheel Assembly, Semi-Pneumatic, Urethane (6" x 2")	1	1
12	D	1115179	Wheel Assembly, Semi-Pneumatic, Urethane, Deep Profile, Grey Tire/Black Hub (6" x 2")	1	1
12	D	1122066	Wheel Assembly, Semi-Pneumatic, Urethane, Deep Profile, Grey Tire/Black Hub (6" x 2") (Pair)	2	1
13		1025726	Screw, Hex Head (7/16-20 x 3-1/4")	1	1
14	A	1042489	Hardware, Caster Axle	1	2
15	B	1109016-NLA	NLA - Head Tube, Caster with Hardware - Right	1	1
15	B	1109017	Head Tube, Caster with Hardware - Left	1	1

NOTE: A - Includes items 10, 11, and 13 to accommodate 1 side.
 B - Includes items 5, 7-9
 C - Chairs made before 7/14/03. Due to product improvement, it is recommended to order (pair) number 1122066 dated after 7/13/03 so each side matches. The deep profile caster has 2 tread grooves w/ round corners instead of 4 tread grooves w/ square corners.
 D - For chairs made after 7/13/03. The pair number is also used for converting casters on chairs made before 7/14/03.
 E - Chairs built Before 12/1/03. Due to design change, forks need to be replace in pairs.
 F - Chairs built After 11/30/03