



Invacare eForms offer new functionality!

Invacare is pleased to offer you an upgraded solution to your ordering process. Our enhanced order forms allow you to fill out a form electronically, print and fax the form, save and email* it to Customer Service, or maintain the business practices that work for you today. The format has been revised to reveal a cleaner look with electronic selection and input functions.

*Saving and emailing the eForms is available with Acrobat Professional software

If you are using Adobe Reader

- **View** and download all forms
- **Save** blank versions of the forms to your desktop
- **Complete** forms electronically
- **Print** blank or completed forms
- **Fax** completed forms to Customer Service

Please note: The 'Email' button at the end of the form will not work with Adobe Reader. The 'Email' button will only work while using Adobe Acrobat Professional.

If you are using Adobe Acrobat Professional

- **View** and download all forms
- **Save** blank AND completed versions of the forms to maintain electronic records
- **Complete** forms electronically
- **Print** blank or completed forms
- **Fax** completed forms to Customer Service
- **Email** completed forms to Customer Service by using the 'Email' button at the end of the form.

For information on downloading Adobe Reader for free, or purchasing Adobe Acrobat Professional, please visit www.adobe.com.

Top End® OSR Racing Chair: Standard Seat Design

Price List and Order Form

www.topendwheelchair.com

Please fax order to TopEnd at 727-522-1007
For questions call: 800-532-8677 or 727-522-8677

Or order by email: TopEndOrders@invacare.com
To order literature: 800-828-6282



TRANSACTION TYPE:

- Order Quote

Provider Name _____ Date _____ Email _____

Account # _____ P.O. # _____ Phone # _____ Fax # _____

Address _____ City _____ State _____ Zip Code _____

Customer Name _____ Email _____ Phone # _____

Address _____ City _____ State _____ Zip Code _____

Ship order to: Provider Customer

Sales Order Number _____

Order will ship to Provider unless otherwise noted.

Internal Use Only

ELIMINATOR OSR FRAME TYPE

'V' or 'Open V' Cage Racing Chair Complete

ELMOSR pages 1 and 96-259-SV1 \$3,145.00

'I' Cage Racing Chair Complete

ELMOSR pages 1 and 96-259-SI1 \$3,145.00

FRAME OPTIONS

ELM29 Aluminum Solid Seat \$75.00

ELM40 Cut-out Axle: Distance \$250.00

Cut-out axle creates more room for legs and lower rear seat heights.

2" Axle Distance See Above

3" Axle Distance See Above

4" Axle Distance See Above

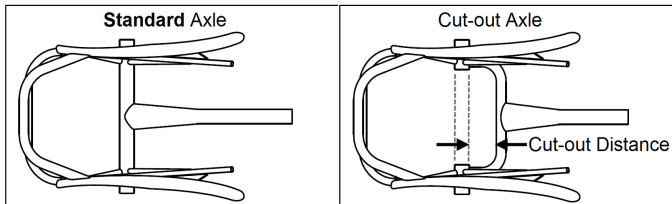

UPHOLSTERY

Knee Length _____ Standard

Amputee Length _____ Standard

Amputee upholstery primary designed for above knee double amputees. Indicate length of upholstery. Knee upholstery can be used in either the traditional position with plastic footplate/strap or kneeling position.

STEERING AND TRACK CONTROL

STEERING HANDLES

- Horizontal **Standard**
 Vertical No Charge

TRACK CONTROL

- Aluminum Triangle **Standard**
 ELM32 Titanium track control and steering mechanism: Triangle \$400.00
 ELM32 Titanium track control and steering mechanism: Oval \$400.00

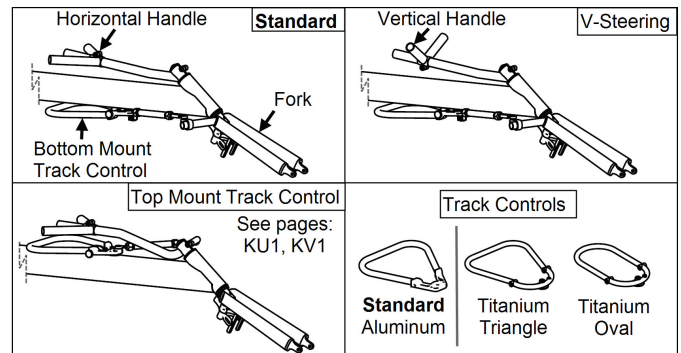

FRONT WHEEL

- 20" **Standard**
 ELM23 20" Carbon Fiber Front Wheel \$600.00

Race 101 CAD Drawings..... \$100.00

Email address required _____

Comments

All prices subject to change without notice. All prices in U.S. dollars. All orders F.O.B. Pinellas Park, Florida USA

For the most current pricing information go to www.invacare.com.

Top End® OSR Racing Chair: Standard Seat Design

REAR WHEELS/PUSHRIMS

REAR WHEELS/TIRES

- 28 Spoke Rear wheels/tires: Clincher **Standard**
- 28 Spoke Rear wheels/tires:Tubular No Charge
- Composite Wheel Upgrade (standard tires not included)
- ELM6 Corima® Carbon fiber 4 spoke (700C) \$2,500.00
Tubular only.
- ELM27 Zipp carbon disk (700C) \$2,250.00
Tubular only.

RUBBER-COATED ALUMINUM PUSHRIM 3/8" 14 DOUBLE PEG

- 12" Diameter Standard
- 13" Diameter Standard
- 14" Diameter Standard
- 15" Diameter Standard
- 16" Diameter Standard

SAFETY AND COMFORT OPTIONS

- Plastic footplate with strap No Charge
- ELM4 Fixed Footrest \$200.00
- ELM10 Helmet \$75.00
 - Small (6 5/8" – 7") See above
 - Medium (6 7/8" – 7 1/2") See above
 - Large (7 1/4" – 7 5/8") See above
- ELM11 Cordless computer \$125.00
- XLT141 Heart Rate Monitor \$100.00
- XLT20 Bike Rack for Trailer Hitch \$450.00
 - 1 1/4" See above
 - 2" See above
- TER124 Click strap small (pad length ~ 8") \$75.00
- ELM12 Additional 2" strap \$20.00
Length _____
- ELM19 Cushion \$75.00
- XLT33 Alignment Gauge \$75.00
- RACE 4 Wheelbag \$180.00
Dealer discount not applicable to RACE options.
- RACE 5 Top End racing suit (Short sleeve – one size fits all) ... \$100.00
Dealer discount not applicable to RACE options.
- RACE 22 Top End T-Shirt \$10.00
Dealer discount not applicable to RACE options.
 - Large See above
 - XLarge See above

FRAME COLOR

UPHOLSTERY

- Black Standard
- UPH1 Woodland Camouflage \$100.00
- UPH2 Digital Desert Camouflage..... \$100.00

CONTEMPORARY COLORS

- 24P Wet Black No Charge
- 115P Black Prism No Charge
- 29P White Snow No Charge
- 60P Silver Metallic No Charge
- 71P Silver Vein No Charge
- 134P Copper Penny No Charge

WAY COOL COLORS

- 62P Electric Blue No Charge
- 105P Midnight Blue No Charge
- 122P Cosmic Blue No Charge
- 127P Grasshopper Green No Charge
- 125P Emerald Green No Charge
- 104P Electric Teal No Charge

TOO HOT COLORS

- 117P Tangerine Red No Charge
- 120P Grape Madness No Charge
- 132P Safety Yellow No Charge
- 116P Sunkissed Orange No Charge

Comments

NOTE: All specifications and dimensions are approximate.
For the most current pricing information go to www.invacare.com.

Invacare Corporation

www.invacare.com

TOP END

Sports and Recreation Products
 4501 63rd Circle North
 Pinellas Park FL USA
 33781-5914

©2010 Invacare Corporation

All rights reserved. Trademarks are identified by the symbols ™ and ®. All trademarks are owned by or licensed to Invacare Corporation unless otherwise noted. Products designated by ASL are Manufactured by Adaptive Switch Labs, Inc. Sun® is a registered trademark of Sun Components Inc. Spinergy™ is a registered trademark of Spinergy Corp. Schwalbe is a registered trademark of RALF BOHLE GmbH in Reichshof Germany. Frog Legs is a registered trademark of Frog Legs, Inc. Kenda is a registered trademark of Kenda Rubber Industrial Co. Ltd. Specifications and prices are subject to change without notification.



ELIMINATOR STANDARD OSR 'V' OR 'OPEN 'V' CAGE (SV1)

CAGE TYPE

- V Cage
- Open V Cage

1. Rear Upper Frame Width _____

2. Lower Frame Width _____

3. V Depth

- 24"
- 25"
- 26"

4. Cage Depth (15" Std.) _____

5. Axle Position _____

6. Rear Seat Height _____

7. Front Seat Height _____

8. Camber

- 11°
- 12°
- 13°
-

9. Overall Length

- 64"
- 66"
- 68"
- 70"
- 72"
- 74"
- 76"

10. Rear Wheel Size

- 700C
- 26"

11. Track Control

- Bottom Mount (standard)
- Top Mount (Not available on Overall Lengths less than 70")

12. Rear Wheel Type

- Zipp
- Corima
- Tri-Spoke
- Standard

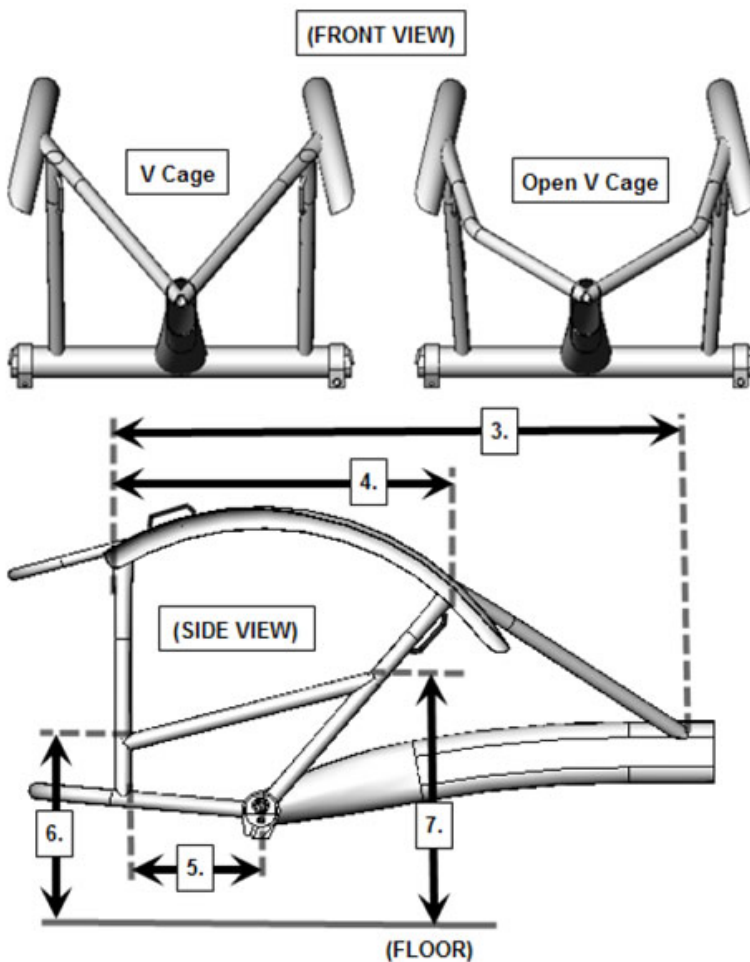
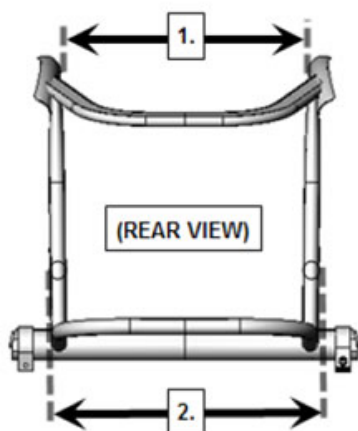

Comments

ELIMINATOR OSR I CAGE (SI1)

- 1. Upper Frame Width _____
- 2. Lower Frame Width _____
- 3. Depth (15" Std.) _____
- 4. Front Seat Height _____
- 5. Rear Seat Height _____
- 6. Axle Position _____
- 7. Camber
 - 11°
 - 12°
 - 13°
 - 15°

- 8. Overall Length
 - 64"
 - 66"
 - 68"
 - 70"
 - 72"
 - 74"
 - 76"
- 9. Rear Wheel Size
 - 700C
 - 26"
- 10. Track Control
 - Bottom Mount (standard)
 - Top Mount (Not available on Overall Lengths less than 70")
- 11. Rear Wheel Type
 - Zipp
 - Corima
 - Tri-Spoke
 - Standard

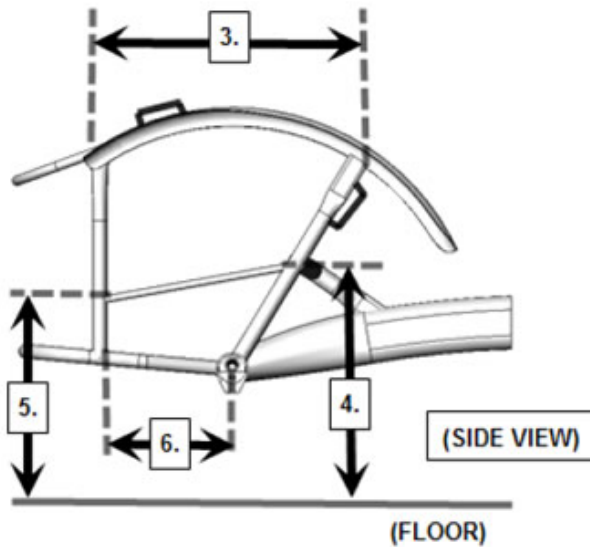
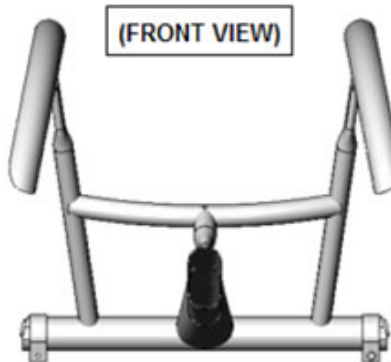
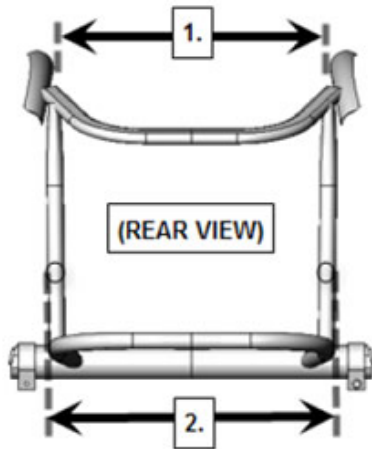

Comments

Top End® OSR Racing Chair: Standard Seat Design

Measuring Guidelines

Standard Seat Design Chair - Is recommended for customers who sit in traditional position and/or eventually want to kneel. Recommended for athletes with limited balance or for T-10 SCI level and above. These athletes need more of a bucket or squeeze and this frame offers this and new users.

Cage Style – Cage styles can be seen on pages SV1 and SI1. V Cage is for the advanced racer with good flexibility to transfer and assume the kneeling position. This cage style is stiffer and more aerodynamic. Open V offers an easier transfer than the V Cage and is better for racers with longer or thicker/big legs. I cage is the easiest for transfers but is less stiff than V or Open V cage styles. Often ordered with optional fixed footrests.

Upper Inside Frame Width – This measurement on the chair is the point directly above the axle on the inside of the frame. This usually rides below the lats on the chair user. With the new integral fender, frame gradually gets wider as the fender follows the wheel. This allows room for the stroke follow through. Measure 2" above waist, then measure straight across chest. Typically upper frame is a maximum 1" – 2" narrower than lower seat width.

Lower Inside Seat Width – Inside panel measurement at rear seat rail. The side panels are riveted on the side of frame as standard. Snug is preferred. Use two flat objects (such as books) to press flesh in at the hips and measure straight across.

Axle Position – Typically between 5" – 8". The lower the level of SCI, the more forward the axle position. Minimum for kneeling position is 6". Most of the top racers have between 6 1/2" – 8". Taller people may need the axle more forward (8") and amputees back a bit (5" – 6"). A straight camber tube (new in 1995) increases the stiffness of the chair and includes rear wheel alignment adjustability. The angled camber tube continues to be an option for those needing more room for their feet.

Camber – Most users prefer 11°. Athletes who sit high and/or race on the track sometimes prefer more.

Seat Height - Measured from floor to the top of the seat rail. Standard is 17" rear and 18" front. The 1" difference gives a slight bucket for stability. Trunk length should also be considered: a long trunk may sit lower and short trunked people, higher. The kneeling position requires a minimum of 17" rear and 18" front to allow room for legs and feet.

Rear Seat Height – Measured from floor. Low level SCI athletes tend to sit higher, whereas quads and high level SCI athletes sit lower. Trunk length should also be considered: a long trunk may sit lower and short trunked people higher. The standard rear seat height is 17".

Overall Length – Measured from end to end (rear to front wheel) – between 64" and 76". The average male adult measures between 72" – 76". This measurement for everyone is dependent on the ability to reach the steering system and brake comfortably with tucked into the racing position. A longer chair is smoother gliding and runs straighter, but if it's too long, the ability to "hop" the chair by body force will diminish.

Rear Wheel Size – 700C – most adult men and women. The larger wheel equals more top end speed and is a must for the serious racer. The Top End Eliminator wheel covering fender helps shorter armed people use a 700C wheel as the wheel is covered and protects against chaffing.

Front Wheel – 20" is standard.

Rear Axle – Standard on Top End racers is 1/2" as this makes a stiffer wheel.

Aero Bars – Are standard on the OSR. Steering mounted on the top of the frame for easier reach and improved aerodynamics with removable bar ends.

Rubber Coated Pushrims – Average is 14 1/2" for men, 14" for women. This depends on arm length and power. Range is 13" – 16". Most good racers have tried many sizes over time.

Standard Accessories – Caliper hand brake is mounted on the left steering handle. 3 positioning straps are included (25", 30", 35"). The tool kit includes a pouch that attaches to the back of the upholstery. 5 Allen tools for assembly/adjusting of rear wheels, pushrims, headset, front wheel and side guards are included.

All prices subject to change without notice. All prices in U.S. dollars. All orders F.O.B. Pinellas Park, Florida USA

For the most current pricing information go to www.invacare.com.